

crash barrier esp 4.0

ESP 4.0 is a single sided barrier generally used in verges to protect against hazards 2.3m or over from the edge of carriageway.

- ❑ Containment Level N2
- ❑ Impact Severity A
- ❑ Working Width W5
- ❑ Post Spacing 4m
- ❑ Overall Height 0.75m

ESP4.0 ACAD DRAWING

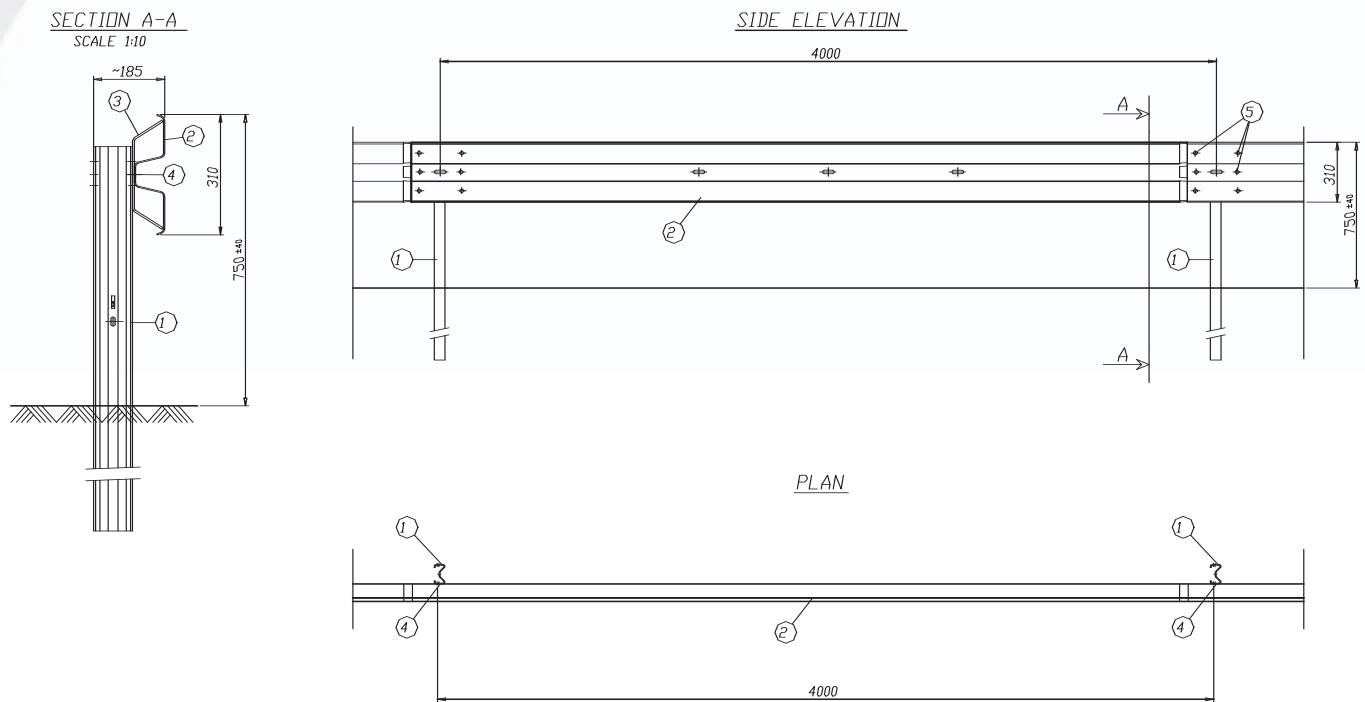

PDS.	MATERIAL DESCRIPTION
1	SIGMA POST 100x55x4,2 H=1900 mm
2	BEAM PROFILE "B" HOLES C/C 1333, 3 mm THICK
3	SPACER "C" 280x78x5 L=70 mm
4	M10 BOLT CLASS 4.6
5	M16 BOLT CLASS 4.6