

crash barrier - edsp 1.3

EDSP 1.33 is a single sided barrier generally used in verges where added protection is required against hazards 1.9m or over from the edge of carriageway.

- ❑ Containment Level H1
- ❑ Impact Severity A
- ❑ Working Width W4
- ❑ Post Spacing 1.33m
- ❑ Overall Height 0.75m

EDSP1.3 ACAD DRAWING

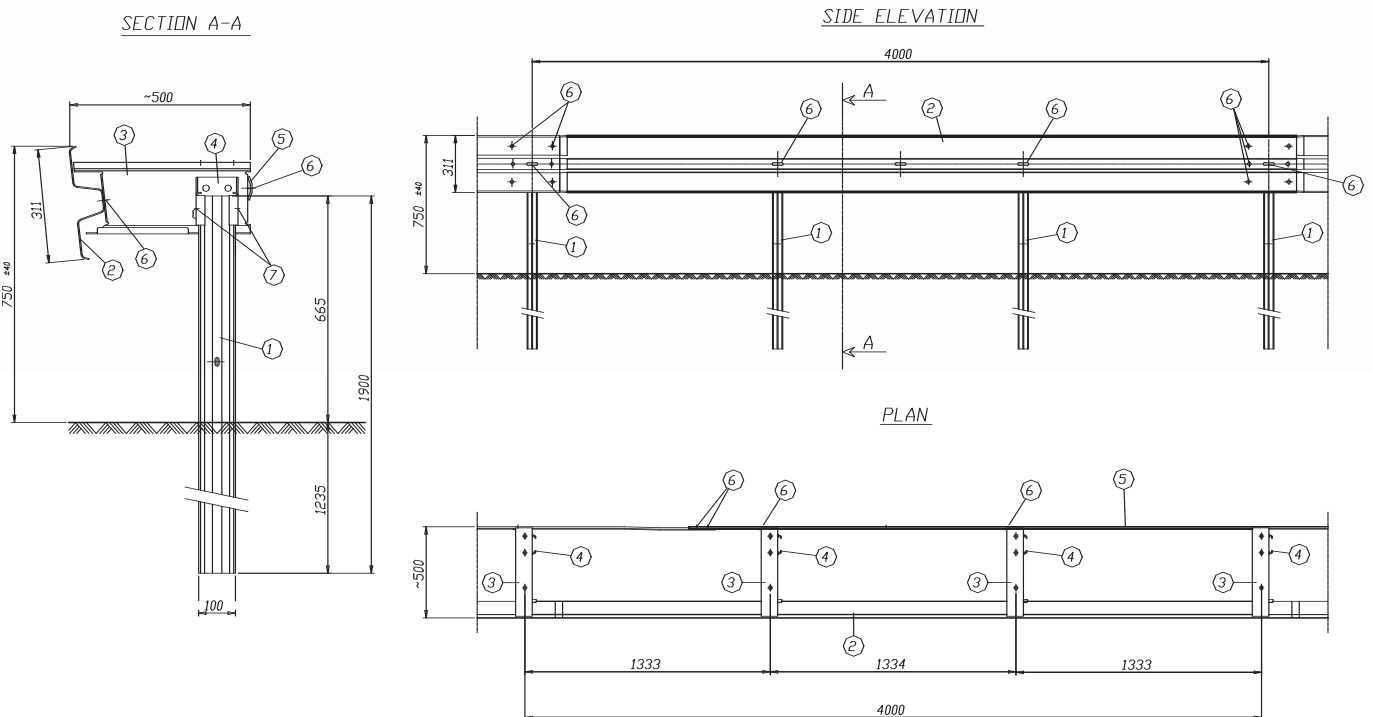

PDS.	MATERIAL DESCRIPTION
1	SIGMA POST 100x55x4.2 H=1900 mm
2	BEAM PROFILE "B" HOLES C/C 1333, 3 mm THICK
3	SPACER 780x194 mm
4	TOP POST SLEEVE C114x69x130 mm
5	TENSION PLATE 70x5 mm
6	M16 BOLT CLASS 4.6
7	M10 BOLT CLASS 4.6